

Operation

- Intended for use with 1 or 3 Phase, 50/60Hz
- Accepts 208-600VAC $\pm 10\%$
- Short Circuit (RMS, Symmetrical)
Stand-Alone Overload Unit - 200 KAIC, 600V Max.
Standard Starter - See UL label on panel
Combination Starter - See UL label on panel
- Ambient Operating Temperature = -20°C to 60°C
- Ambient Storage Temperature = -40°C to 85°C

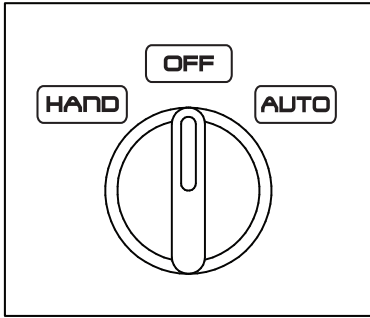

- Ensure that all connections are properly torqued and enclosure is closed prior to applying power to the device.
- Ensure all mechanical equipment operated by the starter is clear for safe operation in case of starter activation.
- When in AUTO mode, starter may be activated remotely by the control system



Operation Modes

HAND

Place the switch in the HAND position to manually start the motor.

OFF (RESET)

Place the switch in the OFF position to manually stop the motor. Additionally, the OFF position serves as a manual reset. Place the switch in the OFF position for 5 seconds to reset the starter after a fault trip.

AUTO

Placing the switch in the AUTO position will allow the starter to be controlled by a remote Start/Stop command through IO terminals D1 & D2.

Setting Adjustments

Overload

Set the overload dial to the SFA amperage value listed on the motor nameplate. If no amperage value for SFA is provided, set the overload dial to the FLA listed on the motor nameplate.



Submersible pumps can develop very high pressure in some situations. Always use a properly selected and installed pressure relief valve to prevent damage and injury from over-pressurization of pipes and tanks.

I/O Descriptions

TERMINAL BLOCK	DESCRIPTION
D1 / D2	<u>Dry Auto Input</u> - When closed, the starter will run when in Auto Mode. (N.O. dry contact or transistorized input)
O1 / O2	<u>Fault Relay Output</u> - Normally open relay contacts that closes in the event of a fault condition. 120VAC, 0.6A
For the above: Use 12-20AWG wire for I/O terminal blocks	
TERMINAL	DESCRIPTION
D3 / D4 / D5	<u>Pilot Device Input</u> - Connections for a 3-position (HOA) switch for motor control. (Wired from manufacturer on N3R enclosed units)
C- / C+	<u>Contactor Output</u> - Provides a 24V output to close the contactor when the motor starter is commanded in either HAND or AUTO mode. Once the contactor is closed, the output drops to 2-4V to maintain contactor closure while optimizing efficiency. Only for use with FCS contactor with 24VAC coil (24V, 0.875A Max).
For the above: Use 14-26AWG wire for I/O terminals, torque to 3.5 lb-in	

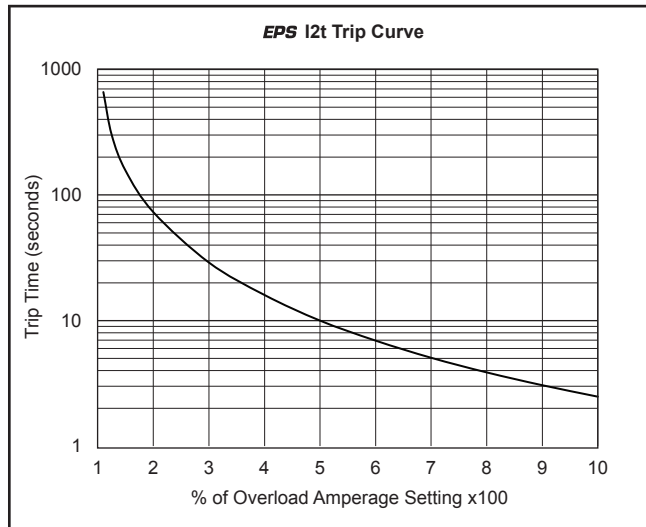

Installation & Operation Guide



Precautions

To prevent injury and property damage, follow these instructions. Failure to adhere to installation/operation procedures and all applicable codes may result in hazards as indicated by warning codes outlined below:



indicates an imminently hazardous situation which, if not avoided, will result in death or serious injury. This signal word is to be limited to the most extreme situations.



indicates a potentially hazardous situation which, if not avoided, could result in death or serious injury.



indicates a potentially hazardous situation which, if not avoided, may result in minor or moderate injury. It may also be used to alert against unsafe practices.



This is the safety alert symbol. Read and follow instructions carefully to avoid a dangerous situation.



This symbol alerts the user to the presence of "dangerous voltage" inside the product that might cause harm or electrical shock.

Safety Instructions



Equipment can start automatically. Lockout/tagout before servicing.



As with all electrical products, read manual thoroughly. Only qualified, expert personnel should perform maintenance and installation. Contact the nearest authorized service facility for examination, repair, or adjustment. Do not disassemble or repair unit unless described in this manual; death or injury to electrical shock or fire hazard may result. Specifications and manual data subject to change. Consult factory for additional information.

Installation



HAZARDOUS VOLTAGE

- Disconnect and lock out all power before installing or servicing equipment.
- This equipment may require locking out multiple power sources prior to service
- Install and wire in accordance with all applicable local & national electrical and construction codes

FAILURE TO FOLLOW THESE INSTRUCTIONS MAY RESULT IN DEATH OR SERIOUS INJURY

Mounting

Mount the starter on a vertical surface, with the line terminals facing up.

CE compliant Installations

To conform to the EMC directive a ferrite core is required on the input of the starter module. Consult the factory for the recommended part number. For a CE compliant installation, all electrical connections must be made by a qualified electrical technician.



- To maintain overcurrent and short-circuit protection, the manufacturer's instructions for selecting current elements and setting the instantaneous-trip circuit breaker must be followed.
- Tripping of the instantaneous-trip circuit breaker is an indication that a fault current has been interrupted. Current-carrying components of the magnetic motor controller should be examined and replaced if damaged to reduce the risk of fire or electric shock.
- Do not locate starter in an environment subject to flammable gases, dusts or materials. Contact arcing can induce explosion or fire.
- Locate starter in a location appropriate to enclosure ratings and operational ratings.
- Do not allow any metal shavings or debris from installation to enter enclosure.

Wiring

Wire main power input and motor leads to the appropriate terminals tightened to specified torques indicated in the Torque Table below. Use only copper conductors rated at least 60°C. Maintain proper clearances and verify that no possibility of an electrical short exists between the power conductors or enclosure. Ensure that wires are not under stress and all insulation is intact.

Low Voltage Wiring

Automation system control wiring should be run in a separate conduit. The control terminal blocks accept 20~12AWG.

Torque Table

Starter	Input (lb-in)		Output (lb-in)
	Standard	Combination	Motor Leads
EPS-S0	NA	70	20
EPS-S0P	NA	70	20
EPS-S1	NA	70	20
EPS-S1P	10.6	70	20
EPS-S2	10.6	70	35
EPS-S3	NA	70-132	45
EPS-S3P	61	70-132	45

Protective Features

Hardware Fault	Trips in the event of a circuit board failure. <i>Note: Contactor terminals C+ & C- are for use with a Franklin Control Systems contactor only. Do not connect to any other devices.</i>
Unexpected Current	Trips if there is current through the CTs at start up.
Contactor Over Current	Trips if the starter's current drawn from the 24V contactor terminals exceeds the rating of the contactor coil.
Overload	Trip current = 115% of dial setting. Trips when the load is greater than the trip current. (I ² t trip curve)
Current Phase Unbalance	Trips in the event of phase loss of if any 1 phase deviates by more than 80% of average.

*In the event of a power failure, the starter will return the last mode it was in (Hand, Off, or Auto) within 10 seconds.

Electronic Overload Operation

When an fault trip occurs, the fault LED will illuminate. The type of fault will be indicated by flashing a combination of the HAND/OFF/AUTO/RUN/FAULT LEDs as indicated in the table below.

FAULT	FLASHING LED
Hardware Fault	RUN & FAULT LEDs
Unexpected Current	OFF LED
Contactor Overload	OFF & AUTO LEDs
Overload	HAND & OFF LEDs
Phase Loss	HAND, OFF, & AUTO LEDs

Wiring Schematic*

EPS Contol Wiring

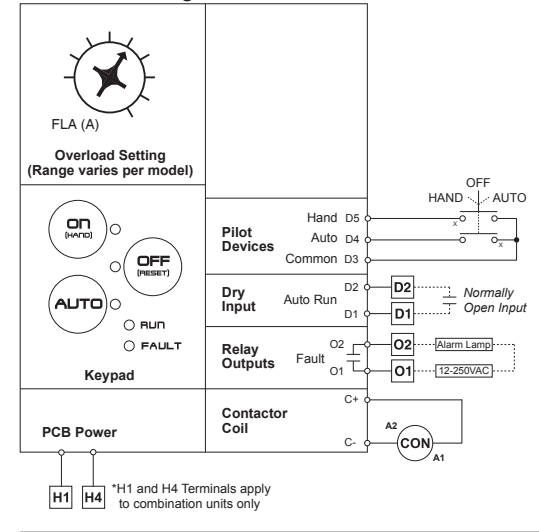

EPS POWER WIRING

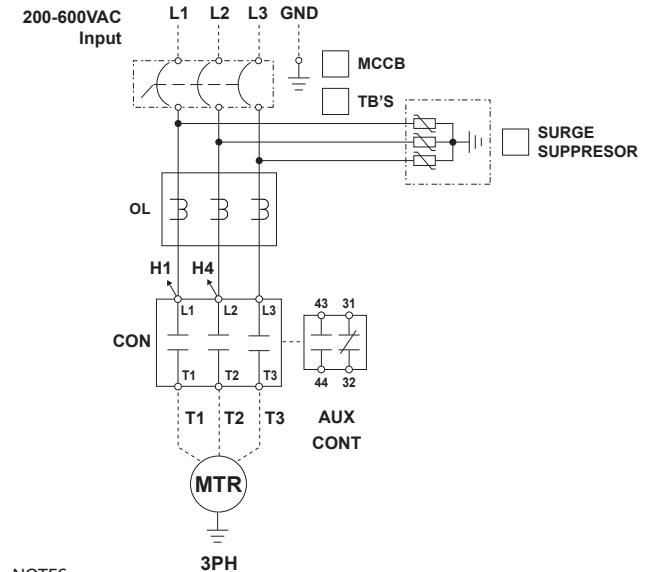

NOTES:

- 1) DASHED LINES INDICATE FIELD WIRING
- 2) CHECKED BOXES INDICATE FACTORY INSTALLED OPTIONS

*Standard product wiring diagram shown. As-built product wiring may vary. Product wiring diagram located on starter enclosure.